

HOUSING FOR STRAIGHT PLUG

R197.112.G90

Series : **SMB**
CARLOCK

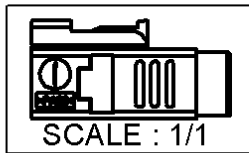
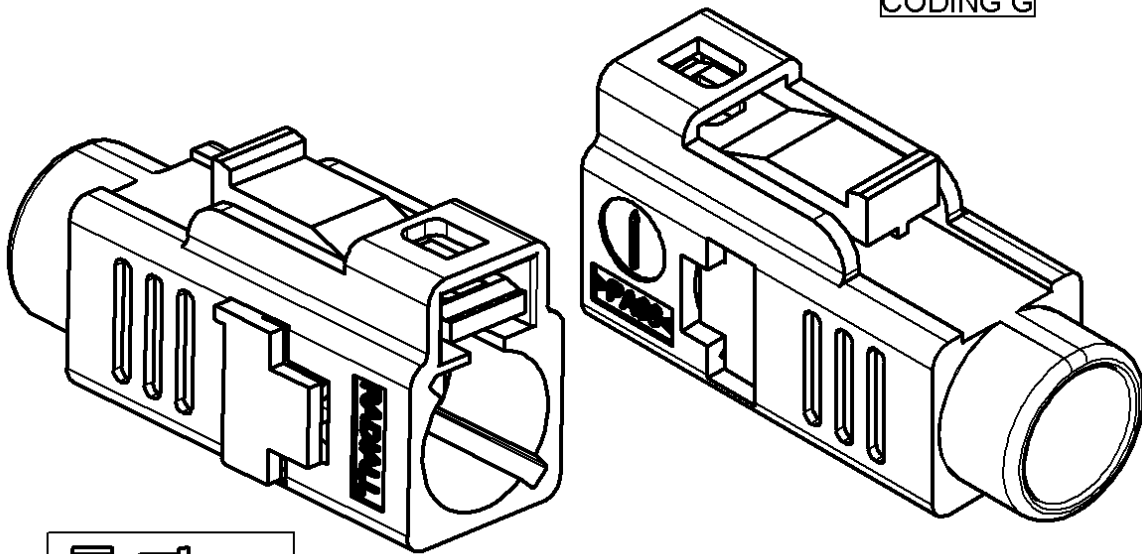
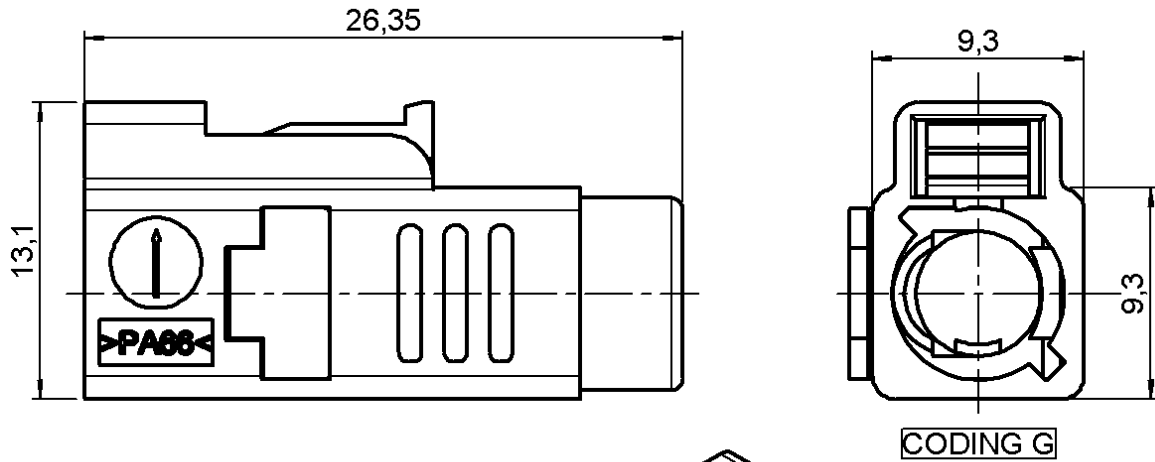

All dimensions are in mm.



COMPONENTS		MATERIALS	PLATINGS (µm)	
HOUSING SECONDARY LOCK	PA66		UL CLASSIFICATION	COLOR
	PA66		UL 94 V-2	GREY Ral7031
			UL 94 V-2	PURPLE Ral4006

*According to FAKRA specifications

Issue : 0334 A

In the effort to improve our products, we reserve the right to make changes judged to be necessary.



HOUSING FOR STRAIGHT PLUG

R197.112.G90

Series : **SMB**
CARLOCK

PACKAGING

SPECIFICATION

Standard	Unit	Other
100	'W' option	Contact us

QS9000

ELECTRICAL CHARACTERISTICS

ENVIRONMENTAL

Impedance Ω
 Frequency GHz
 VSWR + **0.000** x F(GHz) Maxi
 Insertion loss $\sqrt{F(GHz)}$ dB Maxi
 RF leakage - (- F(GHz)) dB Maxi
 Voltage rating Veff Maxi
 Dielectric withstanding voltage Veff mini
 Insulation resistance M Ω mini

Operating temperature **-40/+110** ° C
 Hermetic seal Atm.cm3/s
 Panel leakage

OTHERS CHARACTERISTICS

Assembly instruction **Page 3 & 4**

Others :

HOUSING FOR COAX
R114.082.325,R114.086.325,R114.089.325

MECHANICAL CHARACTERISTICS

Center contact retention
 Axial force – Mating end N mini
 Axial force – Opposite end N mini
 Torque N.cm mini

Recommended torque
 Mating N.cm
 Panel nut N.cm

Mating life **100** Cycles mini
 Weight **1.736** g

Issue : 0334 A

In the effort to improve our products, we reserve the right to make changes judged to be necessary.



HOUSING FOR STRAIGHT PLUG

R197.112.G90Series : SMB
CARLOCK***RECOMMENDED MOUNTING PROCEDURE***

1

- Push the coax until it stops at the bottom of the housing

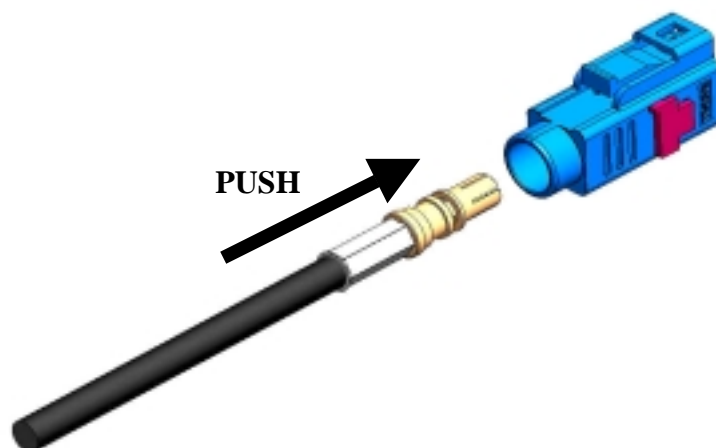

2

- Push the secondary lock in final position to secure the coax inside the housing (until it click on)

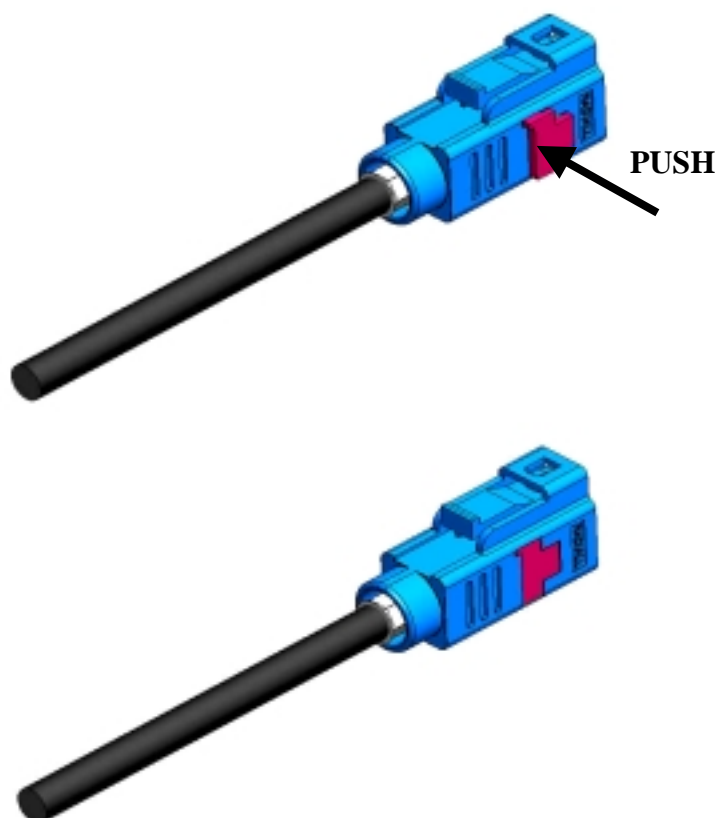

Issue : 0334 A

In the effort to improve our products, we reserve the right to make changes judged to be necessary.



HOUSING FOR STRAIGHT PLUG

R197.112.G90Series : SMB
CARLOCK**RECOMMENDED DISASSEMBLING PROCEDURE**

1

- To unlock the coax from the CPA devise, push the secondary lock from the material marking side until it click on

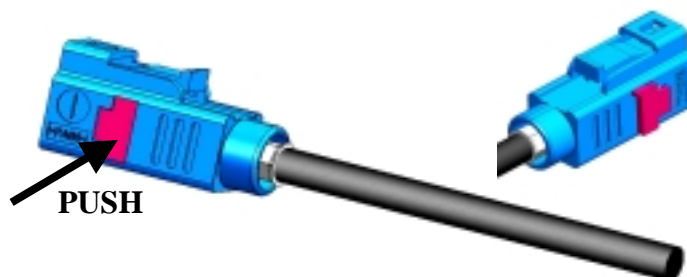

2

- insert a screw driver between the elastic finger and the slot of the housing as shown on the picture.
- Tip up the screw driver as shown on the picture to lift up the elastic finger and when it is done pull on the cable assembly to remove the coax from the housing.

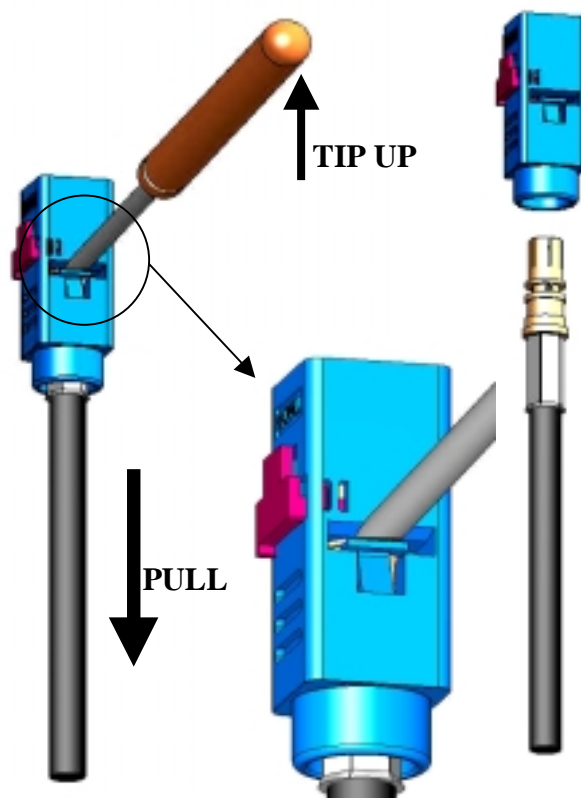

Issue : 0334 A

In the effort to improve our products, we reserve the right to make changes judged to be necessary.